

HZ-3310D
Transformer DC
Winding Resistance Tester



Dear user:

Thank you for choosing HZ-3310D Transformer DC Winding Resistance Tester.

We hope that this instrument can make your work easier and more enjoyable, so that you can get the feeling of office automation in the test and analysis work.

Before using the instrument, please read this manual, and operate and maintain the instrument according to the manual to prolong its service life.

"Just a light press, the test will be completed automatically" is the operating characteristics of this instrument.

If you are satisfied with this instrument, please tell your colleagues; if you are not satisfied with this instrument, please call (0312) 6775656 to tell you to serve you at all times-Baoding Huazheng Electric Manufacturing Co., Ltd., our company will definitely make you satisfied !

Contents

I.General.....	1
II.Safety Measures.....	1
III.Performance Characteristic.....	2
IV.Technical Index.....	3
V. System Description.....	3
VI.Testing And Operation Methods.....	5
VII.Precautions.....	13
VIII.Common Problems And Solution Methods.....	14
IX.After Sale Service.....	16
X.Packing List.....	22

I.General

DC resistance of transformer is one testing item which must be tested during ex-work test of semi-finished products and final products, installation, acceptance test and preventive test of electric power department, which can effectively find out material selection of transformer coil, welding, looseness of connection part, missing strand, broken wire etc manufacturing defect and existing hidden problems after operation. In order to meet rapid measurement demand of transformer DC resistance, our company has researched and developed new generation DC resistance testing meter on basis of its own technology advantage. The instrument applies new brand power technology, which is characterized with small volume, light weight, big output current etc. The whole machine is controlled by a single chip microcomputer, which has automatic self-inspection, data process, display etc functions, it also has automatic discharge and discharge audio alarm and indication etc functions. Testing accuracy of instrument is high, operation is easy and simple, and it can realize rapid measurement of transformer DC resistance.

II.Safety Measures

- 1、 Ensure to carefully read the manual prior to use the instrument.
- 2、 The instrument operator shall have general application knowledge about electric equipments or instruments.
- 3、 The instrument can used indoor and outdoor, it shall avoid application location with rain, corrosive gas, heavy dust, high temperature, direct sun shining etc.
- 4、 The instrument is high precision instrument, it shall avoid violent vibration.
- 5、 Only professional personnel is allowed to carry out repair, maintenance and commissioning of the instrument.
- 6、 When testing is complete, ensure to switch off power supply and disconnect testing line after discharging alarm is stop.
- 7、 Switch shift of transformer only after discharge alarm sound is stop during measurement of no-load voltage regulating transformer.

- 8、 Prohibit disconnect and move testing clip and power supply line during testing.

III.Performance Characteristic

- 1、 This instrument can automatically select output current (maximum output can reach 10A).
- 2、 Measurement scope is wide (0Ω-100Ω) , which can measure transformer, current and voltage transformers etc inductive DC resistance.
- 3、 The display applies 480*272 large lattice 65K colour screen, the displayed data is clear and legible.
- 4、 The instrument has perpetual calendar, 100 groups of data storage, temperature automatic conversion etc functions, data will not be lost after shutdown.This machine is also equipped with the printer which can output and print testing data. "U disk" interface is available, which will facilitate data importing for review.
- 5、 The instrument is equipped with RS485 communication interface, remote control measurement can be realized after upper position computer operation and control software is installed.
- 6、 This instrument is equipped with three same testing functions so as to cope that one line connection of the star type wiring winding can complete measurement of three phases DC resistance, automatically calculate three phases unbalance rate and greatly save measuring time and improve working efficiency. Also apply phase by phase testing function, carry out phase by phase testing for the transformer applying YN and D (Y) connection way, automatically calculate three phases unbalance rate after testing is complete.

This instrument is also equipped automatic magnetic assist function. The high voltage and low voltage series exciting method is applied for testing windings of five columns core low voltage angle wiring transformer. The magnetic assist circuit in the instrument which is automatically connected into windings can quickly and accurately test DC resistance of low voltage windings.

- 7、 This machine has audible discharging alarm, discharging indication is clear and

mis-operation is reduced.

- 8、 This machine has protection and alarm function to protect input against misconnection with AC 380v power supply, which reduces damage on the instruction caused by mis-operation. This machine also has perfect back EMF protection arc prevention capability.
- 9、 This machine is characterized with wide applicable temperature, high accuracy, shake resistant, anti-interference, high stability, convenient carrying etc.

IV. Technical Index

- 1、 Output current: 0~10A (Automatically select according to measuring scope)
- 2、 Measuring scope: 0~100Ω
- 3、 Accuracy: 0.2%±0.2μΩ
- 4、 Minimum resolution: 0.1μΩ
- 5、 Working temperature: -20~40℃
- 6、 Ambient humidity: ≤80%RH, no dewing
- 7、 Working power supply: AC: AC220V±10%, 50Hz±1Hz
- 8、 Volume: 420mm length × 320mm width × 200mm height
- 9、 Net weight: 10.6kg

V. System Description

Refer to figure one for instrument panel.

- 1、 AC power supply input and switch: AC220V, 50Hz AC power supply input port for whole machine, with fuse bin, fuse with 2A, and the switch controls switch on/off of power supply for the whole machine.
- 2、 RS485: Standard 485 communication interface.
- 3、 : Earthing terminal serves as enclosure earthing of whole machine, which belongs to protective earthing.
- 4、 IA, IB, IC and IO terminals: current output terminals for measurement of YN

windings.

- 5、 VA, VB, VC and VO terminals: voltage output terminals for measurement of YN windings.
- 6、 Ia, Ib and Ic terminals: current output terminals for measurement of D or Y windings.
- 7、 **Va, Vb and Vc terminals: voltage output terminals for measurement of D or Y windings.**
- 8、 Display: Large screen colourful liquid crystal display, display menu, current value, resistance value and auxiliary information etc.
- 9、 Selection key: selection key for testing way.
- 10、 Reset key: The whole machine returns back to initial status, initialize the instrument and switch off output current.
- 11、 Print key: Print measurement data, input information and memory information etc.
- 12、 Testing key: Press the key after measurement way is selected, the instrument starts to test according to selected current. Press the key again and test again after measurement data is displayed, rebuild data in buffer area so as to be stable as possible.
- 13、 F1 — F4 function keys: change corresponding indication option of liquid crystal display, select and change selected option.
- 14、 Printer: Print current, resistance and auxiliary information results.
- 15、 U disc interface: connect U disc and import data in memory.

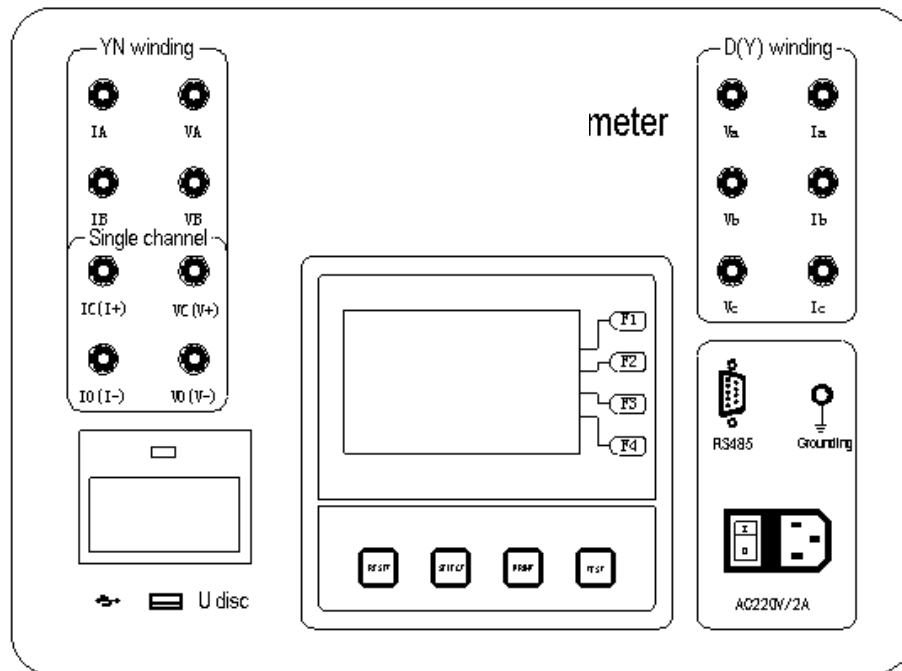

Figure one

VI. Testing And Operation Methods

1、 Connection: Connect tested product with testing terminal of the machine through special cable, large insert of testing cable is connected with current end, small insert is connected with voltage end. Connection shall be firm and protect against looseness.

Connect earth line well at same time. Wire clamps are clamped at two ends of coil resistance of tested product. Refer to following wiring diagram for detailed wiring method, take YND11 transformer as sample. Wiring in following sample is to measure minimum wiring, no winding suspension is led.

The power supply lines supplied with the machine shall be connected to input port AC power supply. Switch on the switch of the power supply, liquid crystal display is lit.

(In case power supply is connected with AC 380V by mistake, the buzzer in instrument which serves as protection will always alarm).

Three channels measurement wiring: (measure YN windings at same time) refer to figure two for wiring.

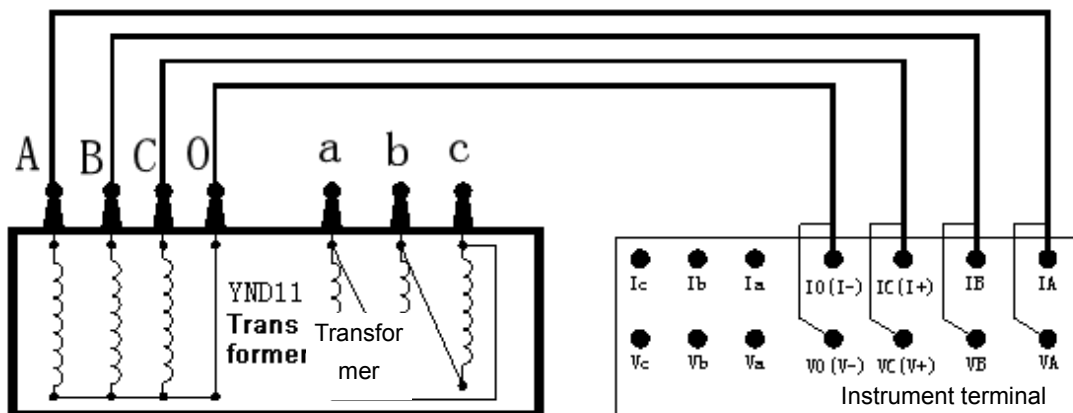

Figure two

Item by item measurement of YN winding: (each phase of YN winding is measured respectively) , refer to figure two for wiring

Item by item measurement of D winding: (each phase of D winding is measured respectively) , refer to figure three for wiring of D winding.

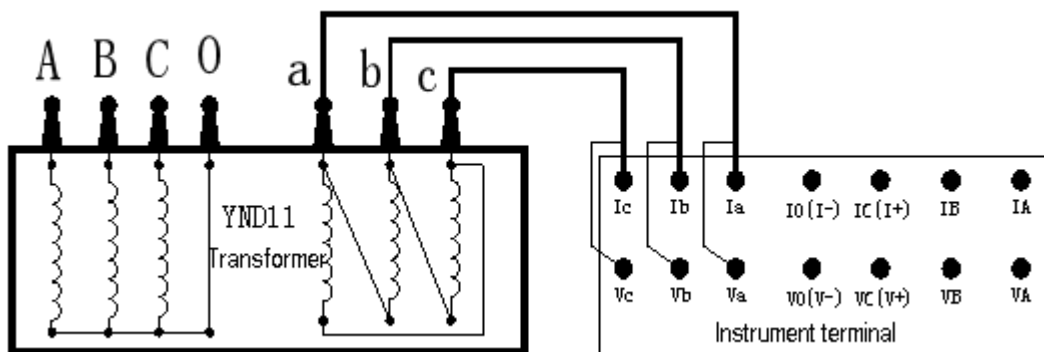

Figure three

Single channel direct measurement wiring: (CO phase measurement of YND11 transformer) refer to figure four.

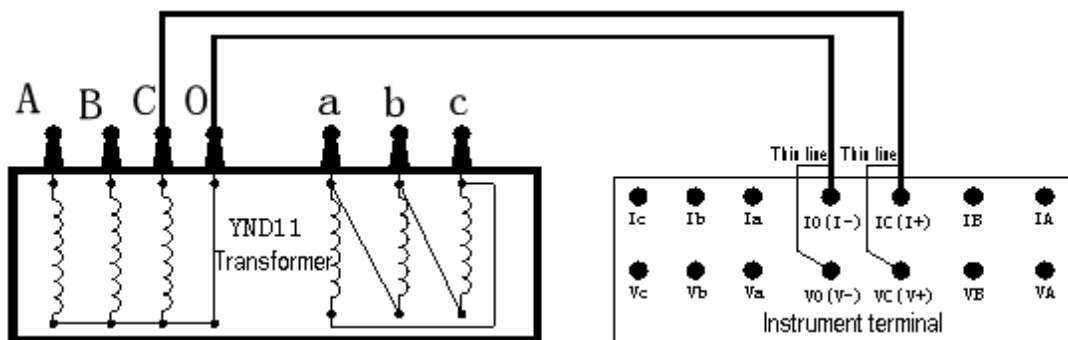

Figure four

Item by item measurement of Y winding: (each phase of Y winding is measured respectively) , refer to figure five for wiring of Y winding.

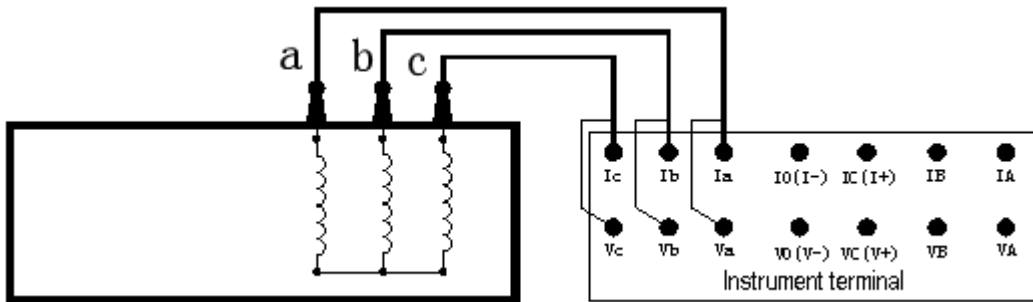

Figure five

Magnetic assist measurement wiring of five columns core YND11 transformer: (Item is optional and low voltage winding is measured item by item under magnetic assist)

Refer to figure six (I)

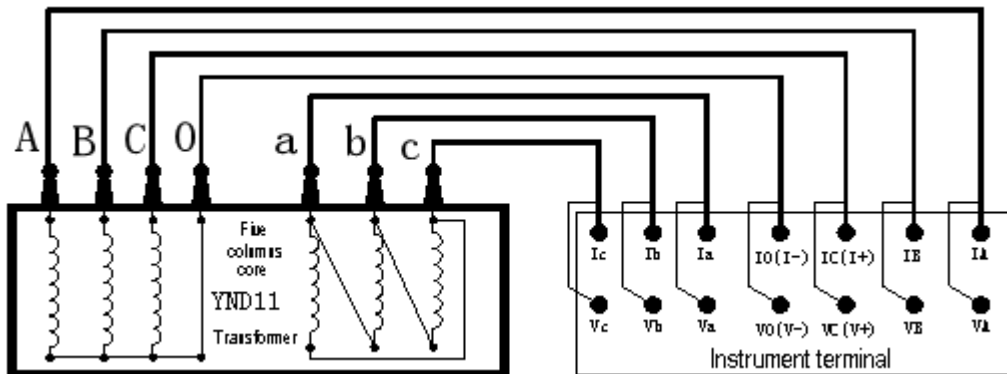

Figure six (I)

The magnetic assist measurement of five columns core YND11 transformer is wired by manual.

Apply single channel method to carry out measurement according to external wiring method shown in figure six (II).

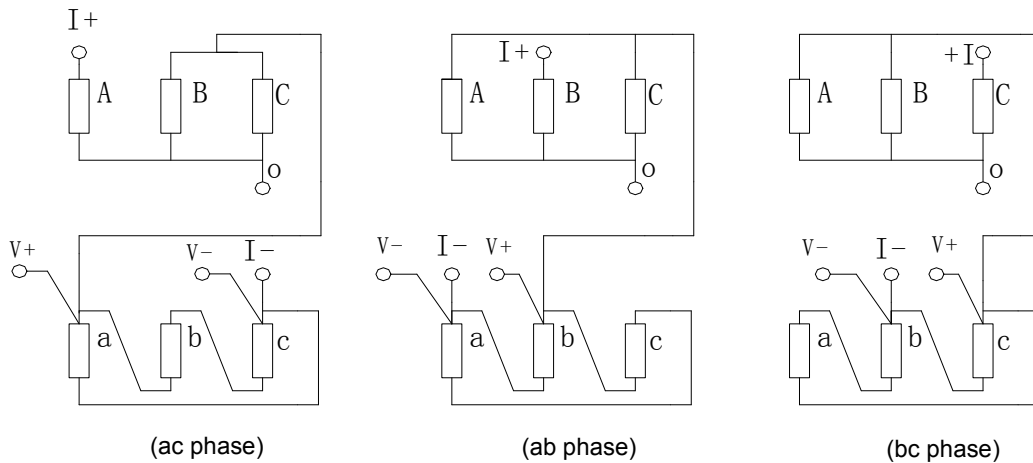

Figure six (II)

2. Start interface: Switch on power supply switch, display the interface as figure three, then automatically skip to selection setting main interface as figure seven after approximate 3 seconds:



Figure seven

3. Selection of measurement way: display of the display screen is shown as interface of figure eight. Select the demanded measurement way through the selection key, the display screen will select corresponding way by circulation. Carefully check whether connection of the testing cable is consistent with the selection way, testing can be carried out only after inspection is correct. Otherwise it will wrongly measure and

affect accuracy of testing results.

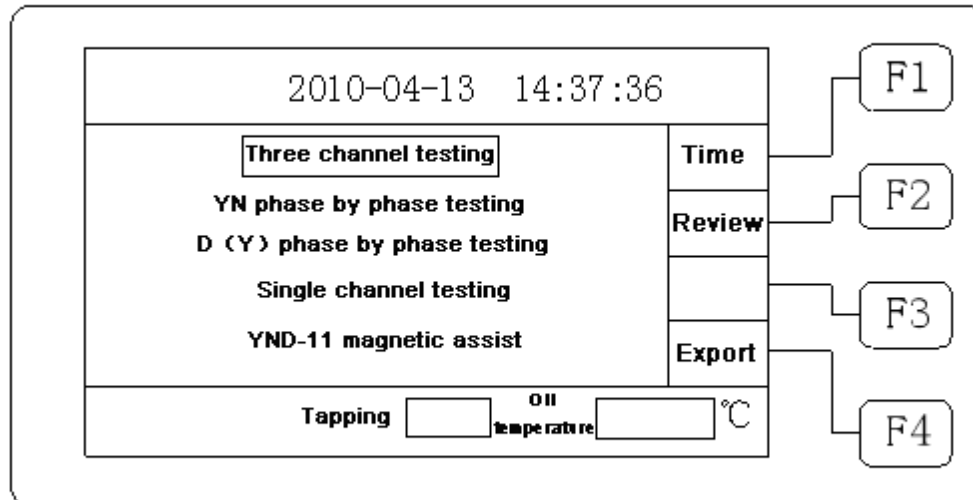

Figure eight

4. Testing: after contents of the measurement way is selected, press down Testing key and start testing. If the selection way is:

“YND-11 magnetic assist”, it will not directly test, the instrument will pop up the magnetic assist selection interface, refer to figure nine, press down corresponding function key and start testing of corresponding functions.

The display screen indicates charging current value and informs “charging ...” at same time, the system clock starts time counting and displays time from charging and starting testing, it will start count again from zero after one hour is expired, which doesn't affect testing process. The screen will display applied testing current after current is stable, indicates “testing ... ” at same time, and then display the interface of the corresponding testing way, observe testing current value and resistance value, instrument continues to test after these values are stable.

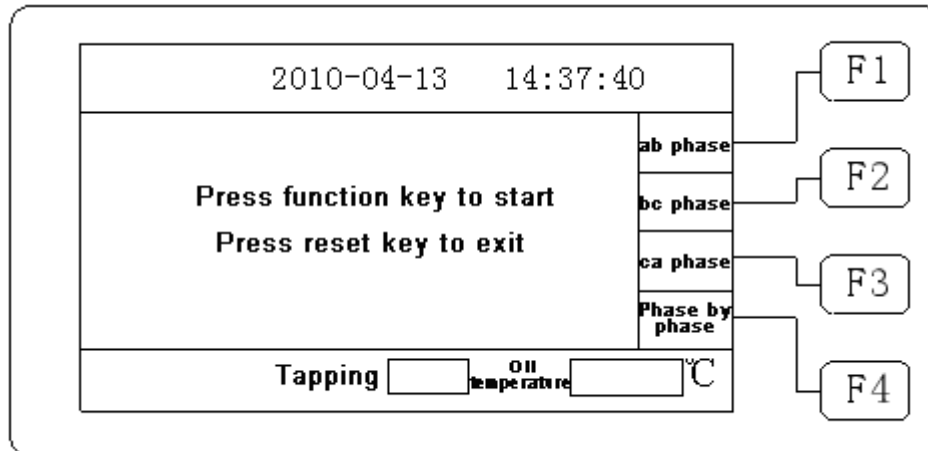

Figure nine

Three channels measurement interface: refer to figure ten

Measurement displays three phases testing resistance value and automatically calculate three phase unbalance rate

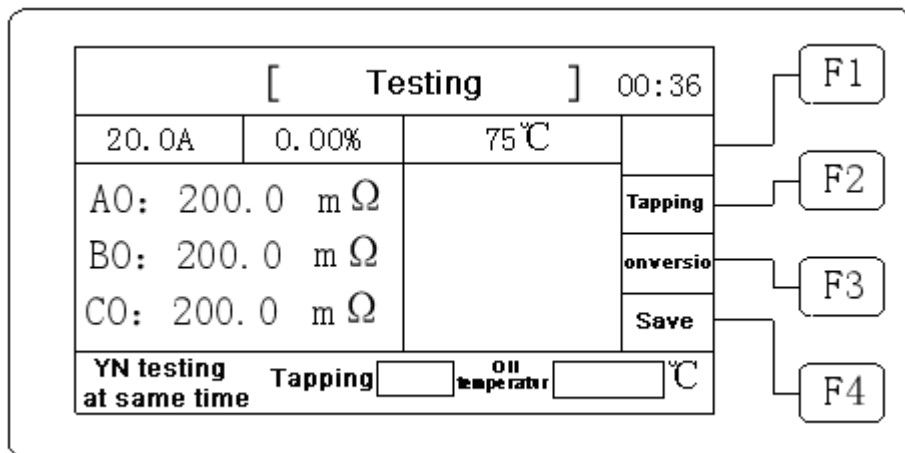

Figure ten

Phase by phase measurement interface: (for example YN phase by phase testing) refer to figure eleven.

The operator shall judge readability of data stability waiting data. Press down "Lock" key to lock data after data are readable, refer to figure twelve, press down "Phase switching" key and start testing of next phase, press down "Return" key,

it will return back to last interface and continues to test stability of the waiting data.

Repeat above operations until testing of three phases are complete, the measurement will display testing resistance value of three phases and automatically calculate three

phase unbalance rate.

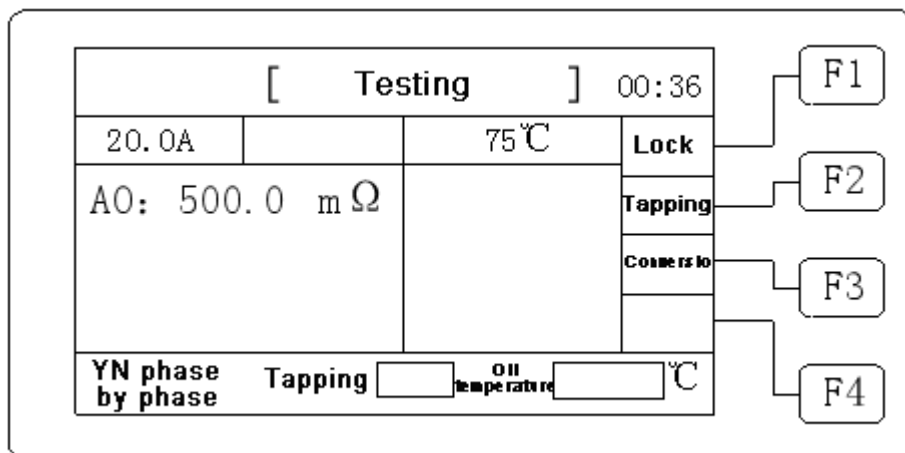

Figure Eleven

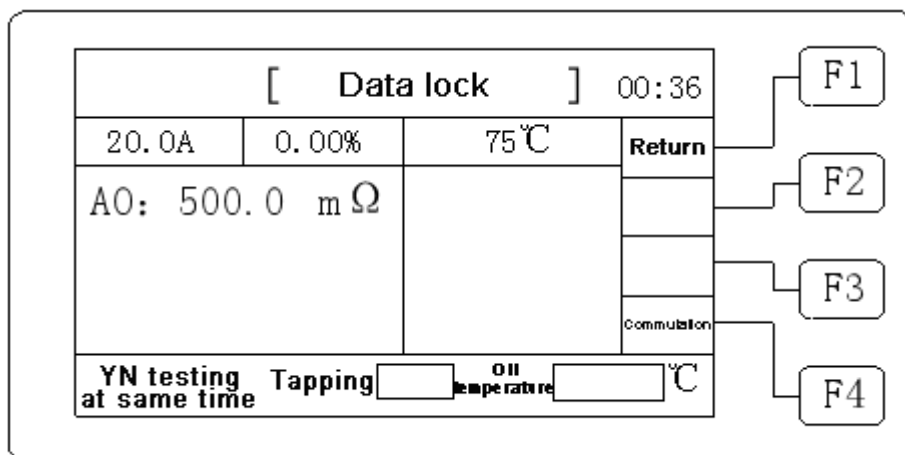

Figure Twelve

“Re-measurement” function, press down “Testing” key and start re-measurement, current is maintained unchanged during continuous data measurement process. The function can clear old data in internal buffer area, measure new data again and make usable data stable as soon as possible.

Auxiliary function, press auxiliary key at right side of liquid crystal display to realize auxiliary function after interface as figure five is displayed

“Conversion” function key, input current temperature of tested product, ranging from - 199.9°C to +199.9°C, after input is complete, press “Confirm” key to exit, and then return back to testing interface, testing interface will be shown as figure thirteen, show temperature and resistance value of tested product and resistance after conversion at

75°C, input again for conversion.

“Tapping” function key, input tapping position of tested sample, from 01 to 60, press down “Confirm” key and exit after input is complete, return back to the testing interface, the testing interface will become figure thirteen.

“Save” function key, press down the save key and information displayed on the screen will be saved in the internal memory so as to facilitate review, print and import to U disc etc operations.

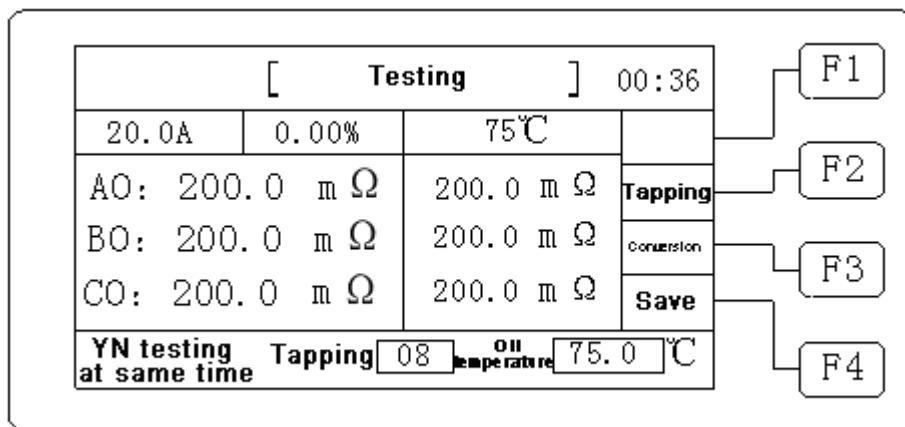

Figure Thirteen

5. After testing is complete, press down “Reset” key, output current of the instrument will be disconnected to the winding, and it is discharged at same time, the audio device alarms, the display screen returns back to the initial status (figure four). It is wired again after discharging of the audio device is complete, carry out next measurement or remove testing wire and power supply wire and finish measurement.
6. Time adjustment: Press “Time” function key in opening machine interface, enter into time adjustment interface and adjust completeness time, press “Confirm” key and return back to interface of opening machine, time revision is complete.
7. Review data: Press “Review” function key in opening machine interface, enter into Reviewing record interface, circularly review, store and review 100 groups of data at maximum, press “Exit” key and return back to opening machine interface.If no data is available for review, it will display “Temporarily no record” and then automatically exit back to starting interface.
8. Import to U disc: Press down “Export” function key on the starting interface, data in

memory of the instrument will be exported. If no data is available for export, it will display "Temporarily no record" and then automatically exit back to starting interface. If U disc isn't connected or connection is fault, it will display "Connect U disc", please insert U disc or check connection. Data will automatically be imported into U disc after it connected well. File name for U disc import is defined as following:

DT100408 Firstly establish a file folder taking day as unit: DT100408

"04" means April; Where, "DT" is a fixed format of file starting; "10" is last two bits of 2010 year; "04" means April.

"08" means No 8.

And then establish file taking hour, minute and second as units: SJ092458

Where, "SJ" is a fixed format of file starting; "09" means 9 clock of morning; "24" means 24 minutes;

"58" means 58 seconds.

Establish file taking export time and establishment time. (System default).

9. "Communication" function, the instrument applies standard RS485 interface, which interfaces RS485 of the instrument with the computer.

The communication control of the instrument, edit and printing etc functions of the testing data are completed by RS485 interface connection with upper position computer operation software. Refer to Appendix "Communication protocol" for communication protocol.

10. "Print" function, press down press key and print out data and information after testing is complete or during data displaying or reviewing.

VII.Precautions

- 1、 Ensure to reset before measuring reverse tapping of no load voltage regulation transformer, switch tapping point only after discharge is complete and alarm sound stops.
- 2、 Prohibit remove and connect testing cable during measurement process. Remove and change wire only after it is reset and discharging alarm sound is complete, so as to prevent against damage to human body and equipments.
- 3、 The transformer with on-load voltage regulation shall start measurement from 1 or 17

maximum resistance shift during resistance measurement of high voltage side.

- 4、 Please refer to measurement scope in technical index column during selection of the measurement way, don't use over measurement scope.
- 5、 It is better to apply high voltage magnetic assist method to save measurement time for measurement of low voltage side windings of large capacity five columns core YND11 transformer.
- 6、 Middle voltage and low voltage star type windings which are not applicable to test three phases at same can apply YN phase by phase testing.

VIII.Common Problems And Solution Methods

- 1、 Don't start and buzzer continues sound

Firstly check whether power supply is connected with AC380V or voltage of input power supply is too low under such condition.

- 2、 Crystal screen can't be lit when machine is started.

Firstly check whether power supply is normal in case of this situation, then check whether fuse is broken. If it is broken, replace new fuse.

- 3、 Liquid crystal screen for starting machine is lit but display is abnormal or not display

Firstly start again and press re-set key once under such condition.

- 4、 Testing data isn't stable or error is too great

Firstly check testing wire whether it is virtually connected and loose under such condition.

If it isn't still solved, check whether the sample is corroded.

- 5、 Always display "Charging" during testing process

Firstly exclude magnetic circuit problem of the transformer in case of this situation. If the current isn't changed for long time and it is always around zero, check whether there is short circuit phenomenon in the circuit. If current isn't always charged, check whether measurement scope is exceeded.

- 6、 "Exceed measurement scope". If resistance value is greater than 50Ω during testing process, it will inform "Exceed measurement scope", the instrument will not stop testing, and it will continue display testing result. But the measurement result may be inaccurate, it belongs normal phenomenon.

7、 “Overheat protection” Temperature may rise up because the power supply in the instrument works for long time or is damaged, it will inform “Overheat protection”. Start the machine and don’t carry out testing, let the air fan work for 10 minutes and let internal temperature drop down as soon as possible, and then carry out testing. If it can’t be tested, power supply may be damaged.

In case above problem can’t be solved by yourself, please contact us in time

IX.After Sale Service

Product shall be repaired and replaced free of charge in case of product quality problem in 12 months from procurement date, guarantee and technical service are provided for whole service life of the product. In case any abnormal condition or fault is found in the instrument, please contact the company in time so that we can organize most convenient treatment plan for you.

Advantage And Disadvantage Comparison Between YN

Attachment: Three Channels And YN Phase By Phase Measurement Method

一、 **Disadvantage and advantage comparison of YN three phases at same side and YN phase by phase measurement**

1. Measure three phase resistance at same time, greatly shorten working time;
2. Data are collected for three phases at same time when the high temperature is just shut down, avoid influence of temperature change on the balance degree of three phases;
3. Reduce influence of oxidation film of voltage regulation switch contact on the unbalance degree of three phases.

二、 **Disadvantage of comparison between YN three phases at same side and YN phase by phase measurement**

1. Because magnetic circuit is firstly established for first group data and there is mutual influence between three phases, so stability time is slightly longer;
2. For the transformer with voltage regulation switch, there is great error in resistance value because of influence of oxidation film even though balance degree of three phases is qualified, be careful when data are filled in test report;
3. No current passes through leading part of the neutral point, it can't demonstrate whether leading line of the neutral point is normal, one data of each phase shall be demonstrated according to single phase way.
4. The measurement value doesn't include leading resistance of the neutral point. In order that the coil resistance is approximated, there is error between ex-work values of the transformer, analyze as following in detail.

(Assume current $I_1 = I_3$ $I_2 = 2I_1$)

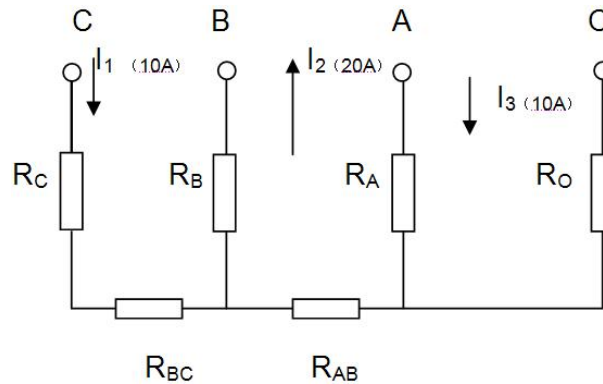

C phase { Single phase measurement, $R_{CO} = R_C + R_{BC} + R_{AB} + R_O$ (ex-work value of transformer)
 Three phases measurement, $R_{CO} = R_C + R_{BC} - R_{AB} \approx R_C$ (coil resistance of C phase)

B phase { Single phase measurement, $R_{BO} = R_B + R_{AB} + R_O$ (ex-work value of transformer)
 Three phases measurement, $R_{BO} = R_B + \frac{1}{2}R_{AB}$ (coil resistance of B phase)

A phase { Single phase measurement, $R_{AO} = R_A + R_O$ (ex-work value of transformer)
 Three phases measurement, $R_{AO} = R_A$ (coil resistance of A phase)

Seen from above results: A phase and C phase measure coil resistance (not including resistance of neutral point) during three phase's measurement. Resistance of B phase measurement coil is added with half resistance of leading wire of A phase and B phase (not including resistance of neutral point).

Approximate resistance of coil can be obtained with this way. Resistance of the neutral

point isn't measured, there is negative error when it is compared with ex-work value.

YN phase by phase measurement applies commutation way to measure three windings item by item on basis of above disadvantage, calculate unbalance rate after measurement is complete. But data stability shall be judged by manual and commutation is operated by manual. One charging and charging shall be carried out for each commutation, testing time is long, but data have no above error.

Communication Protocol

1 Interface form:RS485/232RS485/232

Baud rate: 9600 bps, 1 start bit, 8 digit bits, no calibration, 1 stop bit

2 Function description:

- (1) The master machine can control the slave machine to carry out testing.
- (2) The master machine can set the measurement scope.
- (3) The master machine can review status of the slave machine at any time.
- (4) The master machine can control reset of the slave machine at any time.

3 Message format: except that message header and message trailer apply binary respectively, other fields of the message apply ASCII code to transmit.

Description of communication format:

Address of slave machine: 2 bytes ASCII code value, high byte in the former, address of slave machine is 45H 45H

Data: command parameters or data of measurement results which are actually transmitted, data of master machine are contents which parameters shall be transmitted.

Send command of master machine:

1	2	3	4	5	6	7	8	9				
Message header	Address of slave machine is high	Address of slave machine is low	Length of data and command are high	Length of data and command are low	Command of master machine	Data	Data	Data	...	Data	Exclusive or calibration	Message trailer

Echo data of slave machine:

1	2	3	4	5	6	7	8	9				
Message header	Address of slave machine is high	Address of slave machine is low	Length of data and command are high	Length of data and command are low	Status of slave machine	Data	Data	Data	...	Data	Exclusive or calibration	Message trailer

4 Send command of master machine: command of master machine consists of three categories:

Testing/re-measurement command A(41H), parameters (testing way) setting command B(42H), resetting command C(43H),print command C(44H), locking command C(45H), return command C(46H), commutation command C(47H).

1. Testing/re-measurement command: command is 41H

Corresponding data sequence list is expressed as following: **7E 45 45 30 31 41 3E 0D**

2. Reset: command is 43H

Corresponding data sequence list is expressed as following: **7E 45 45 30 31 43 3C 0D**

3. Print: command is 44H

Corresponding data sequence list is expressed as following: 7E 45 45 30 31 44 XOR 0D

4. Lock: command is 45H

Corresponding data sequence list is expressed as following: 7E 45 45 30 31 45 XOR 0D

5. Return: command is 46H

Corresponding data sequence list is expressed as following: 7E 45 45 30 31 46 XOR 0D

6. Commutation: command is 47H

Corresponding data sequence list is expressed as following: 7E 45 45 30 31 47 XOR 0D

7. Request data message: 48H is taken as addressing request data command

Corresponding data sequence list is expressed as following: 7E 45 45 30 31 48 37 0D

The slave machine will transmit the current status to the master machine during each request data of the master machine.

(2) Parameter setting: command is 42H + setting value

Corresponding data sequence list is expressed as following: 7E 45 45 30 32 42 30 XOR 0D (YN three phases at same side)

Corresponding data sequence list is expressed as following: 7E 45 45 30 32 42 31 XOR 0D (YN phase by phase testing)

Corresponding data sequence list is expressed as following: 7E 45 45 30 32 42 32 XOR 0D (D phase by phase testing)

Corresponding data sequence list is expressed as following: 7E 45 45 30 32 42 33 XOR 0D (single phase testing)

Corresponding data sequence list is expressed as following: 7E 45 45 30 32 42 35 XOR 0D (magnetic assist ab)

Corresponding data sequence list is expressed as following: 7E 45 45 30 32 42 36 XOR 0D (magnetic assist bc)

Corresponding data sequence list is expressed as following: 7E 45 45 30 32 42 37 XOR 0D (magnetic assist ca)

Corresponding data sequence list is expressed as following: 7E 45 45 30 32 42 38 XOR 0D (magnetic assist phase by phase testing)

6. Data information which is transmitted to the master machine from the slave machine:

Data information status which are returned back to the master machine from the slave

machine consist of eight categories:

Reset status (41H), charging status (42H), overheat protection status (43H), over measurement scope information (44H),Discharging status (46H), testing status (47H), circulation testing completion status (48H),locked data status (45H), commutation status (49H)

- (1) XOR 0D Reset status: 7E 45 45 30 32 41 (information of parameter setting) XOR 0D
- (2) Charging status: 7E 45 45 30 37 42 (information of parameter setting + current data) XOR 0D
- (3) Overheat protection status: 7E 45 45 30 32 43 (information of parameter setting) XOR 0D
- (4) Over measurement scope information 7E 45 45 3x 3x 44 (information of parameter setting + current data + resistance data) XOR 0D
- (5) Locked data: 7E 45 45 3x 3x 45 (information of parameter setting + current data + resistance data) XOR 0D
- (6) Charging status: 7E 45 45 30 32 46 (information of parameter setting) XOR 0D
- (7) Re-testing status: 7E 45 45 30 37 47 (information of parameter setting + current data) XOR 0D
- (8) Circulation testing status: 7E 45 45 3x 3x 48 (parameters + current data + resistance data) XOR 0D

Current data is 5 bits, 4 bits data, one unit (m, K, null), "A" isn't transmitted.

*****Resistance data is resistive data: such as: 1.2345 mΩ expressed as: 31 2E 32 33

34 35 6D*****

expressed as: 31 2E 32 33 34 20 4B

Null is: 20 "Ω" isn't transmitted.

Resistance data of two phases: resistance value 1 (seven bits) + resistance value 2 (seven bits).

Resistance data of three phases:

Resistance value 1 (seven bits) + resistance value 2 (seven bits) + resistance value 3 (seven bits) + unbalance rate (5 bits).

[9] Commutation status: 7E 45 45 30 32 49 (information of parameter setting) XOR 0D

7 Note:

Operation status	Parameter setting	Testing	Reset	Print	Lock	Return	Commut ation
Reset	yes	yes	yes	no	no	no	no
Charging	no	no	yes	no	no	no	no
Testing	no	no	yes	no	no	no	no
Circulation testing	no	yes	yes	yes	yes	no	no
Discharging	no	yes	yes	no	no	no	no
Over temperature protection	no	no	yes	no	no	no	no
Commutation status	no	no	yes	no	no	no	no
Locking data	no	no	yes	no	no	yes	yes
Over measurement scope	no	yes	yes	yes	yes	no	no

PC machine is the master machine, the slave machine doesn't response at any time when the master machine doesn't send out command.

The master machine starts and visits the slave machine (addressing) or sends out command every 400ms, it sends out again in case of fault,it is communication error when it is still fault after three times.

Note 7 is the list to limit operation of the upper position computer, YES means ok and NO means no.

Function of the operation key of the upper position computer shall be limited.

X.Packing List

No.	Item	Qty
1	Main engine	1
2	testing wire	1
3	Three cores power supply cable	1
4	Fuse pipe	2